



passive fire protection and insulation

Suppliers of passive fire products,  
acoustic and specialist insulation  
Manufacturers of the Safire® Fire Stopping Range

Uniclass	EPIC
C1/S1B	

## SAFIRE® BATTS

Fire rated mineral fibre slabs

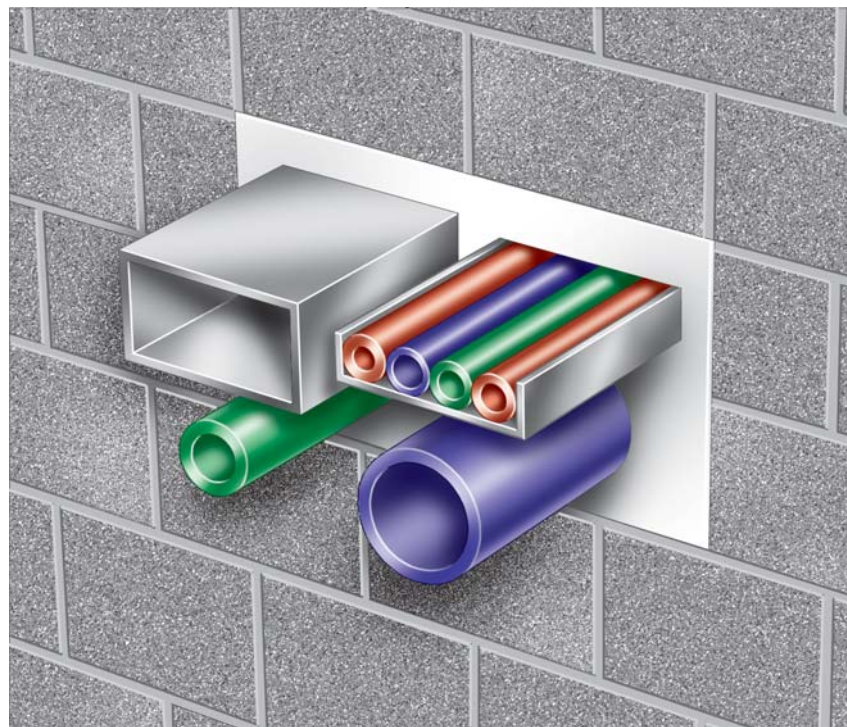

**Cost effective, lightweight fire protection for up to 4 hours for passages through fire rated compartment walls and floors.**

- Lightweight
- Versatile
- Easily Modified
- Waterproof
- Tested to BS EN1363-1 2012, BS EN1366-3 2009



# SAFIRE® BATTS

## Fire rated mineral fibre slabs

Safire Fire Barriers consist of 160kg/m<sup>3</sup> density mineral fibre slabs, factory coated with a white, class 'O' flexible, waterproof ablative coating to produce a durable fire barrier for service penetration openings. They are light, flexible and easy to handle and cut.

### NO DELAMINATION

Safire Barriers are pre-treated with a PVA solution before the application of the fire resistive ablative coating. This treatment consolidates the mineral fibre, assisting the ablative coating to 'key' to the fibre surface.

### SAFE TO USE

Total encapsulation by the PVA and ablative coating prevents fibre migration. Safire Batts are free from asbestos, solvents and halons and can be used with confidence in sensitive areas.

### LIGHTWEIGHT

160kg/m<sup>3</sup> density offering upto 4hours fire resistance.

### WATERPROOF

Safire Batts are waterproof and can be used in high humidity areas.

### EASILY MODIFIED

Safire Batts are easily modified to accommodate additional services installed at a later date, without the need for dismantling the seal.

### RESISTANT & FLEXIBLE

Able to withstand significant vibration of penetrating services and normal building movement.

### CERTIFICATION

Fire Test:  
BMTRADA  
BMT/FEP/F15235, BMT/FEP/F15236

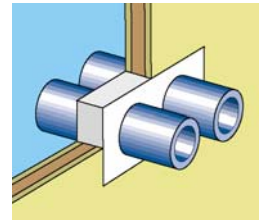
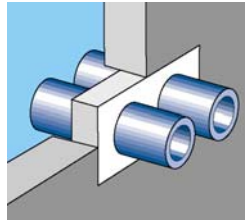
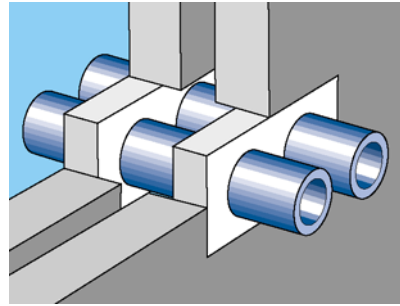

### TECHNICAL SPECIFICATION

PHYSICAL FORM	Crimped rock fibre slabs, factory encapsulated with white acrylic coating
SIZES	1200mm x 600mm x 50mm
DENSITY	160kg/m <sup>3</sup> minimal
COATING DFT	1mm
FIRE RATING	Upto 2hrs per 1 slab (50mm) thickness, coating applied to external facing sides
SOUND REDUCTION	Reduction in excess of 50db can be achieved
APPLICATION TEMPS	1°C to 50°C
SHELF LIFE	N/A
STORAGE TEMP	Avoid frost

### ON SITE SUPPORT

A comprehensive design, advice and support service is offered to architects, specifiers and contractors ensuring trouble free installation.

Other products in the Fireus Products range:

**FIRE BARRIERS:** Total Comfort Rock Fibre Fire Blanket

**FIRE STOPPING:** Compound  
Fire Collars  
Barriers  
Sealants  
Fire Pillows  
Expansion Joints  
Flamestop60

**THERMAL:** Industrial thermal and acoustic insulation

For information on any of the above, or the name of your nearest distributor, please contact our sales department on tel. 01524 388898.

Alternatively, product information is available from our web site at [www.fireus.co.uk](http://www.fireus.co.uk)

Your distributor:



Fireus Ltd.

Unit 6 Thetis Road, Lune Industrial Estate, Lancaster, LA1 5QP

Tel. 01524 388898 | Fax. 01524 383724 | Email. [info@fireus.co.uk](mailto:info@fireus.co.uk) | Web. [www.fireus.co.uk](http://www.fireus.co.uk)